

PETROFLANGE

REDUCCIONES - CONCENTRICAS Y EXCENTRICAS

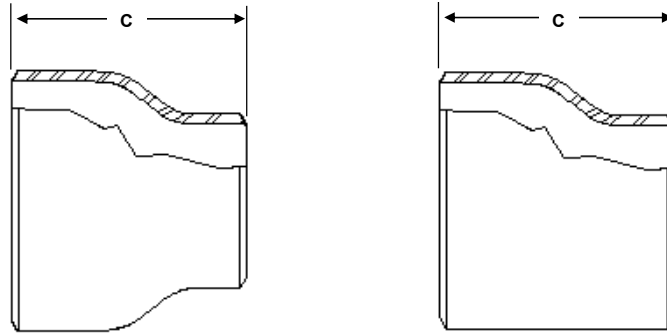

DIAMETRO NOMINAL

BOCA ANCHA	BOCA CHICA	BOCA CHICA	BOCA CHICA	BOCA CHICA	BOCA CHICA	H
3/4	1/2	3/8	—	—	—	1.50
1	3/4	1/2	—	—	—	2.00
1-1/4	1	3/4	1/2	—	—	2.00
1-1/2	1-1/4	1	3/4	1/2	—	2.50
2	1-1/2	1-1/4	1	3/4	—	3.00
2-1/2	2	1-1/2	1-1/4	1	—	3.5
3	2-1/2	2	1-1/2	1-1/4	—	3.5
3-1/2	3	2-1/2	2	1-1/2	1-1/4	4
4	3-1/2	3	2-1/2	2	1-1/2	4
5	4	3-1/2	3	2-1/2	2	5
6	5	4	3-1/2	3	2-1/2	5.5
8	6	5	4	3-1/2	—	6
10	8	6	5	4	—	7
12	10	8	6	5	—	8
14	12	10	8	6	—	13
16	14	12	10	8	—	14
18	16	14	12	10	—	15
20	18	16	14	12	—	20
22	20	18	16	14	—	20
24	22	20	18	16	—	20
26	24	22	20	18	—	24
30	26	24	22	20	—	24
36	30	26	24	22	—	24
42	36	30	26	—	—	24

SE FABRICAN DE CONFORMIDAD CON:

ASTM A-234 EN TODOS SUS GRADOS

WPB, WPC, WP1, WP12 CL1, WP12 CL2, WP11 C L1, WP11 CL2, WP11 CL3, WP22 CL1, WP22 CL3

WP5 CL1, WP5 CL3, WP9 CL1, WP9 CL3, WPR, WP91

CONTROLES DE CALIDAD

ANSI B16.9

ASME A/SA 234 WPB

ASME B16.9

ASME B16.28

MSS SP-75

ASTM A 234/A234M16

NACE MR 0175 ISO 15156